

carpenteria in ferro - impianti industriali

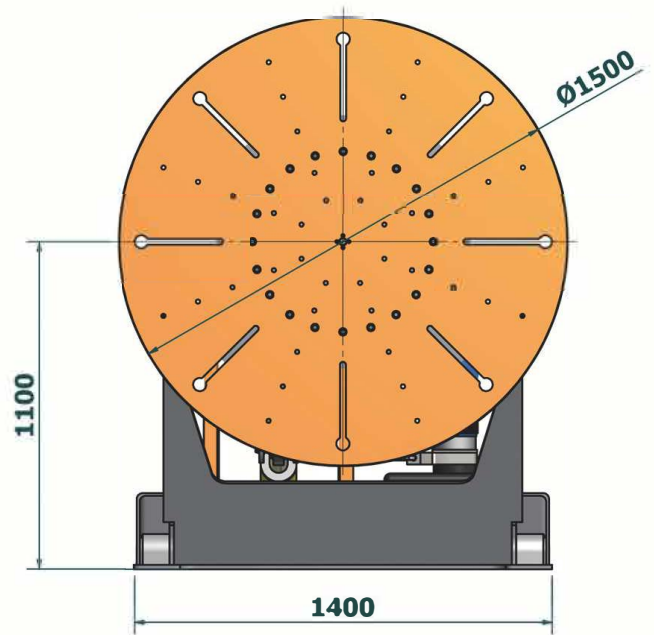

<b>Portata Max tavola orizzontale:</b> .....	<b>3.000 Kg</b>
<b>Portata Max in tutte le posizioni - 0°/120°:</b> .....	<b>1.000 Kg</b>
<b>momento torcente Max :</b> .....	<b>500 Kg/m</b>
<b>momento flettente Max :</b> .....	<b>1.000 Kg/m</b>
<b>Velocita' rotazione tavola:</b> .....	<b>0,05 - 1,5 RPM</b>
<b>Inclinazione tavola:</b> .....	<b>0° - 120°</b>
<b>Peso della macchina:</b> .....	<b>2.200 Kg</b>
<b>Tensione di alimentazione:</b> .....	<b>380V 50Hz 3f</b>
<b>Potenza installata:</b> .....	<b>2,0 Kw</b>
<b>Massa per saldatura:</b> .....	<b>800 A</b>

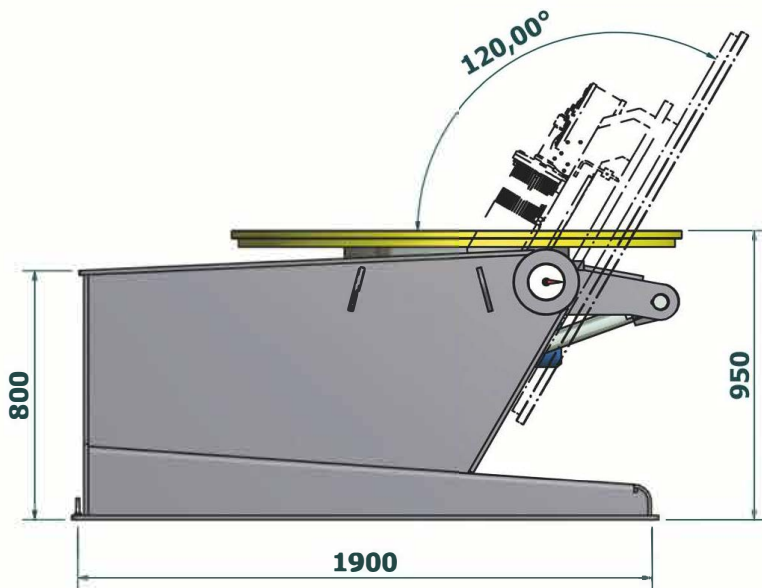