

carpenteria in ferro - impianti industriali

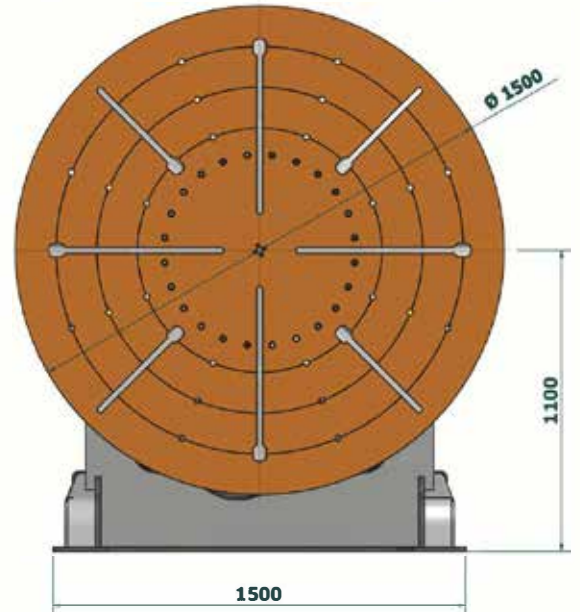

Max capacity with horizontal table:	8.000 Kg
Max capacity in all positions - 0°/110°:	4.000 Kg
Max Torque moment:	1.500 Kg/m
Max Bending moment:	4.000 Kg/m
Table speed rotation:	0,15 - 0,5 RPM
Table tilt:	0° - 110 °
Machine Weight:	3.500 Kg
Supply voltage:	380V 50Hz 3f
Installed power:	5,0 Kw
Mass welding:	1.200 A

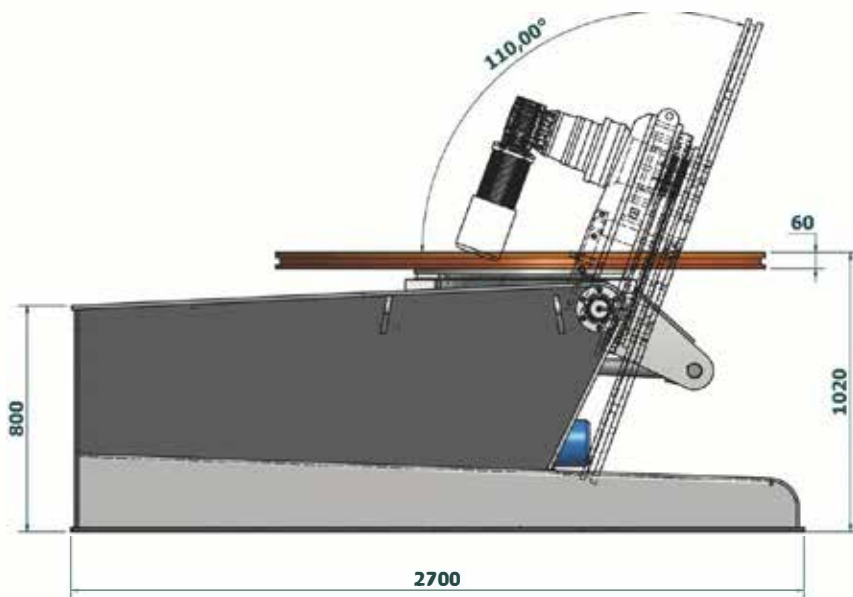